

## TILTIX INCLINOMETER WITH CAN-BUS INTERFACE USER MANUAL



### USER MANUAL INCLINOMETER WITH CAN-BUS INTERFACE

#### **Imprint**

FRABA POSITAL GmbH  
Carlswerkstr. 13c  
51063 Cologne, Germany  
Telefon +49 221 96213-0  
Telefax +49 221 96213-20  
Internet <http://www.posital.com>  
e-mail [info@posital.com](mailto:info@posital.com)

#### **Copyright**

The company FRABA POSITAL GmbH claims copyright on this documentation. It is not allowed to modify, to extend, to hand over to a third party and to copy this documentation without written approval by the company FRABA POSITAL GmbH. Nor is any liability assumed for damages resulting from the use of the information contained herein. Further, this publication and features described herein are subject to change without notice.

#### **Alteration of Specifications reserved**

Technical specifications, which are described in this manual, are subject to change due to our permanent strive to improve our products.

#### **Disclaimer of Warranty**

FRABA POSITAL GmbH makes no representations or warranties, either express or implied, by or with respect to anything in this manual, and shall not be liable for any implied warranties of merchantability and fitness for a particular purpose or for any indirect, special, or consequential damages.

Version date: 18. April 2005

Version number: 1.4

Article number:

Author: Efthimios Ioannidis

### USER MANUAL INCLINOMETER WITH CAN-BUS INTERFACE

<b>1. Introduction</b> .....	<b>4</b>	4.4.1 Guard-Time .....	20
1.1 Inclinometer .....	4	4.4.3 Lifetime-Factor .....	21
1.2 CANopen technology .....	4	4.5 Heartbeat-Function.....	22
1.3 CAN Communication Reference Model .....	6	4.5.1 Heartbeat-Consumer:.....	22
1.4 Definitions .....	7	4.5.2 Programming example:	
<b>2. Installation</b> .....	<b>8</b>	Heartbeat-Consumer.....	23
2.1 Electrical Connection .....	8	4.5.3 Heartbeat-Producer:.....	23
2.2 Bus Termination .....	8	4.5.4 Programming example:	
2.3 Bus address .....	8	Heartbeat-Producer.....	24
2.4 Troubleshooting .....	9	4.6 Changing the node number .....	24
2.4.1 Power on – Inclinometer doesn't respond .....	9	4.6.1 Example: Changing the node number .....	25
2.4.2 Malfunction of the position value during transmission.....	9	4.7 Adjusting the baudrate .....	26
2.4.3 Too much ERROR-Frames.....	9	4.7.1 Example : Adjusting the baudrate .....	27
2.4.4 Information .....	9	4.8 Transmission Mode .....	27
<b>3. Device Configuration</b> .....	<b>10</b>	4.8.1 Cyclic Mode.....	27
3.1. CANopen data transmission .....	10	4.8.2 Disable the cyclic mode.....	28
3.1.1 The COB-ID .....	10	4.8.3 Sync Mode .....	28
3.1.2 The Command Byte .....	11	4.8.4 Example: Number of Sync telegrams .....	29
3.1.3 The Object Directory .....	12	4.8.5 Polled Mode .....	29
3.2 Operational Status .....	14	4.9 Memory Transfer .....	30
3.2.1 Status: Operational .....	14	4.10 Restore default parameters .....	31
3.2.2 Status: Pre-Operational.....	14	<b>5. Technical Data</b> .....	<b>32</b>
3.2.3 Reset of the inclinometer .....	15	5.1. Electrical Data .....	32
3.3 Transmission of the Actual Position .....	15	5.2. Mechanical Data .....	32
<b>4. Programming</b> .....	<b>15</b>	Environmental Conditions .....	33
4.1 Resolution.....	16	5.3 Mechanical Drawings .....	33
4.1.1 Programming example: Resolution .....	17	5.3.1 Bottom View .....	33
4.2 Operating ParameterLongitudinal .....	17	5.3.2 Site View .....	33
4.2.1 Programming example: Operating Parameter Longitudinal .....	18	5.3.3 Front View .....	34
4.3 Preset Value Longitudinal .....	19	5.3.4 Top View .....	34
4.3.1 Programming example: Preset value .....	19	Installation hints .....	35
4.4 Node-Guarding .....	20	<b>6. Models/Ordering Description</b> .....	<b>35</b>
		6.1 Accessories and documentation .....	36

### USER MANUAL

### INCLINOMETER WITH CAN-BUS INTERFACE

#### 1. Introduction

This manual describes the implementing and configuration of an inclinometer with CANopen interface. The device fulfills the requirements of a CANopen device regarding the device specification DS410 of the CANopen user group.

##### 1.1 Inclinometer

The AGS CAN-Bus is a heavy duty absolute inclinometer with conductive technology and a fieldbus interface utilizing the CANBus protocol. With a maximum measuring range of +/- 30° and resolution up to 0.001°, these inclinometers are used in a wide variety of position sensing applications for the measuring of inclinations. Mechanical features include an aluminum housing and IP66 protection. Electrical features include a linear and temperature compensated characteristic line, integrated SMD circuits, and over voltage peak protection. The inclinometer can be connected to a bus via an 8 pin connector. The termination resistor can be switched on by using a dip-switch. In addition the resolution is changeable via SDO object.

For further information about the setup of a CANopen network please refer [http://www.posital.com/products/encoder\\_abc/encoder\\_abc.html](http://www.posital.com/products/encoder_abc/encoder_abc.html)

Open functions. The following modes can be programmed and enabled or disabled:

- Polled Mode
- Cyclic Mode
- Sync Mode

The protocol supports the programming of the following additional functions:

- Resolution
- Preset value
- Baudrate
- Node number

The general use of inclinometer with CAN-Bus interface using the CAN Open protocol is guaranteed.

##### 1.2 CANopen technology

CAN stands for Controller Area Network and was developed by the company Bosch for applications within the automobile area. In the meantime CAN has become increasingly used for industrial applications. CAN is a multi-masterable system, i.e. all users can access the bus at any time as long as it is free. CAN doesn't operate with addresses but with message identifiers. Access to the bus is performed according to the CSMA/CA principle (carrier sense multiple access with collision avoidance), i.e. each user listens if the bus is free, and if so, is allowed to send messages. If two users attempt to access the bus simultaneously, the one with the highest priority (lowest identifier) receives the permission to send. Users with lower priority interrupt their data transfer and will access the bus when it is free again. Messages can be received by every participant. Controlled by an acceptance filter the participant accepts only messages that are intended for it.

##### CANopen

Transmission Technology: Two-core cable  
Baud rates: 20 kBaud up to 1 MBaud  
Participants: maximum 127  
Cable Length: 30 m for 1 MBaud  
5000 m for 20 kBaud

### USER MANUAL

### INCLINOMETER WITH CAN-BUS INTERFACE

The data communication is done via message telegrams. In general, telegrams can be split in a COB-Identifier and up to 8 following bytes. The COB-Identifier, which determines the priority of the message, is made from the function code and the node number.

The node number is uniquely assigned to each user. With the AGS inclinometer this number can be set via SDO object.

The function code varies according to the type of message transmitted:

- Administrative messages (LMT, NMT)
- Service data objects (SDOs)
- Process data Objects (PDOs)
- pre-defined messages (synchronization, emergency messages)

PDOs (Process Data Objects) are needed for real time data exchange. Since this messages possess a high priority, the function code and therefore the identifier are low. SDOs (service data objects) are necessary for the bus node configuration (e.g. transfer of device parameters). Because these message telegrams are transferred acyclicly (usually only while powering up the network), the priority is low.

FRABA inclinometers with CANopen interface support all CANopen functions. The following operating modes can be programmed:

- Polled mode:  
The position value is only given upon request
- Cyclic Mode:  
The position value is written cyclically (interval adjustable) to the bus
- Sync mode:

After receiving a sync message by the host, the inclinometer answers with the current process value. If a node is not required to answer after each sync message, a parameter sync counter can be programmed to skip a certain number of sync messages before answering again

- Change of state mode:  
The position value is transferred when changing

Further functions (preset, resolution,etc..) can be parameterized. FRABA inclinometers correspond with the class 2 profile for inclinometer (DSP 410), whereby the characteristics of inclinometer with CANopen interface are defined.

The link to the bus is made by a 8 pin connector. For configuration and parameterization various software tools are available from different providers. With the help of the provided EDS file (electronic datasheet) simple line-up and programming are possible.

### USER MANUAL INCLINOMETER WITH CAN-BUS INTERFACE

#### 1.3 CAN Communication Reference Model

The communication concept can be described similar to the ISO-OSI Reference Model:

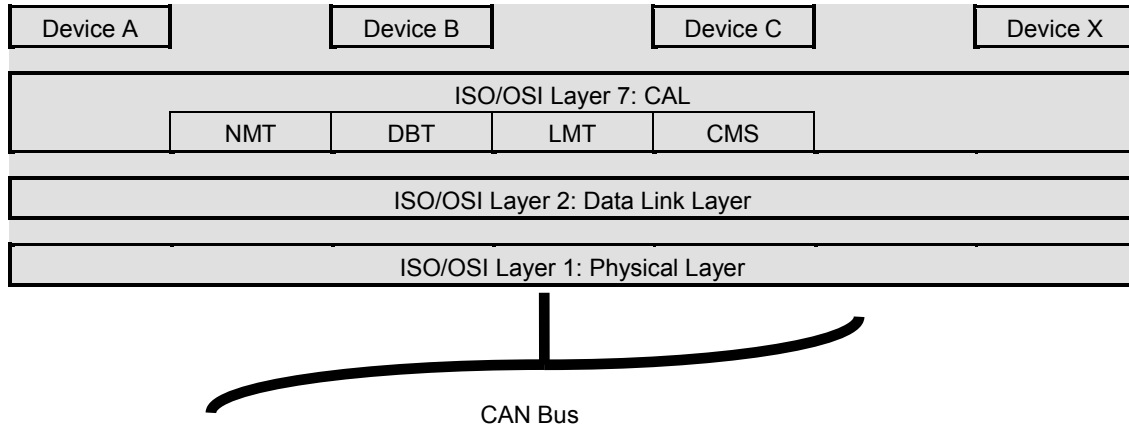

The communication model\* supports synchronous and asynchronous messages. With respect to the functionality four different message objects are provided:

- Administrational Messages (LMT, NMT)
- Service Data Messages (SDO)
- Process Data Messages (PDO)
- Pre-defined Messages (Synchronisation and Emergency Messages)

**Further information is available at:**

CAN in Automation (CiA) International Users and Manufacturers Group e.V.  
Am Weichselgarten 26  
D-91058 Erlangen

(\*) Reference: CAN Application Layer for Industrial Applications

- CiA Draft Standard 201 ... 207, Version 1.1
- CAL-based Communication Profile for Industrial Systems
- CiA Draft Standard 301

### USER MANUAL INCLINOMETER WITH CAN-BUS INTERFACE

#### 1.4 Definitions

<b>CAN</b>	Controller Area Network	Additionally, following abbreviations are used in the manual:
<b>CAL</b>	CAN Application Layer	
<b>CMS</b>	CAN Message Specification. One of the service elements of the application layer in the CAN Reference Model.	
<b>COB</b>	Communication Object. (CAN message) A unit of transportation in a CAN Network. Data must be sent across a Network inside a COB.	<b>FC</b> Function code. It determines the kind of message, which is sent across the CAN network.
<b>COB-ID</b>	COB-Identifier. Identifies a COB uniquely in a Network. The identifier determines the priority of that COB.	<b>NN</b> Node number. It determines uniquely the CAN device.
<b>LMT</b>	Layer Management. One of the service elements of the application layer in the CAN Reference Model. It serves to configure parameters of each layer in the CAN Reference Model.	<b>PV</b> Preset value
<b>NMT</b>	Network Management. One of the service elements of the application layer in the CAN Reference Model. It performs initialisation, configuration and error handling in a CAN network.	<b>PCV</b> Process value
<b>SDO</b>	Service Data Object. A data object with low priority to configure a CAN node.	
<b>PDO</b>	Process Data Object. A data object with high priority to transmit data in synchronous and asynchronous modes.	

### USER MANUAL

### INCLINOMETER WITH CAN-BUS INTERFACE

## 2. Installation

### 2.1 Electrical Connection

The inclinometer is connected via 8 pin round connector

#### Instructions to mechanically install and electrically connect the inclinometer



**Do not connect the inclinometer under power!**



**Do not stand on the inclinometer!**



**Avoid mechanical load!**

Pin	Description
1	24 V Supply voltage
2	
3	
4	0 V Supply voltage
5	CAN Low
6	CAN Ground
7	CAN High
8	

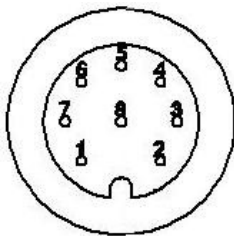

8 pin round connector  
connector male inlay

### 2.2 Bus Termination

If the inclinometer is connected at the end or beginning of the bus the termination resistor must be switched on. The termination resistor is switched on when the dip-switch 8 is in the 'ON' position. To switch the resistor on, the cap of the inclinometer has to be unscrewed.

There is a resistor provided in the inclinometer, which must be used as a line termination on the last device.



### 2.3 Bus address

The setting of the node number is achieved via SDO-Object (see 4.4). Possible (valid) addresses lie between 0 and 96 whereby every address can only be used once.



**The CANopen inclinometer adds internal 1 to the adjusted device address.**



### USER MANUAL INCLINOMETER WITH CAN-BUS INTERFACE

#### 2.4 Troubleshooting

##### 2.4.1 Power on – Inclinometer doesn't respond

Problem:

The bus is active but the installed inclinometer transmitted the false node number.

Possible solution:

- modus pre-operational
- addressing the inclinometer via SDO
- reset or power off
- power on

##### 2.4.2 Malfunction of the position value during transmission

Problem:

During the transmission of the position value occasional malfunctions occur. The CAN bus can be temporarily in the bus off state also.

Possible solution:

Check, if the last bus nodes have switched on the terminal resistor. If the last bus node is an inclinometer the terminal resistor is to activate.

##### 2.4.3 Too much ERROR-Frames

Problem:

The bus load is too high in case of too much error frames.

Possible solution:

Check if all bus node has the same baudrate. If one node has another baudrate error frames are produced automatically. The setting of the baudrate is described in this manual under 4.6.

##### 2.4.4 Information

Notice: The changing of baudrate and node number is only valid after a new power up, NMT Reset or the store parameters command.

### USER MANUAL INCLINOMETER WITH CAN-BUS INTERFACE

## 3. Device Configuration

### 3.1. CANopen data transmission

The data transmission in the CAN network is realised by message telegrams. Basically, these telegrams can be divided into the COB-ID and 8 following bytes as shown in the table below:

COB-ID	Command	Index		Subindex	Service-/Process- Data			
11 Bit	Byte 0	Byte 1	Byte 2	Byte 3	Byte 4	Byte 5	Byte 6	Byte 7
		Low	High		Low	→	→	High

#### 3.1.1 The COB-ID

The 11 Bit of COB-Identifier is built as follows:

10	9	8	7	6	5	4	3	2	1	0			
Function code				Node number									
X	X	X	X	X	X	X	X	X	X	X		X: free selectable	

The COB-Identifier determines uniquely the message object. It is built by the function code, identifying the message class and the node number, which determines the inclinometer. The node number can be adjusted by on customer request by a SDO.

Following function codes are available:

(rx) and (tx) as seen by the master !

Object	Function Code (Binary)	Result. COB-ID	Priority Class*
NMT	0000	0	0
SYNC	0001	128	0
Emergency	0001	129 - 255	0,1
PDO (rx)	0011	385 - 511	1,2
PDO (tx)	0100	513 - 639	2
PDO (rx)	0101	641 - 767	2,3
PDO (tx)	0110	769 - 895	3,4
SDO (rx)	1011	1409 - 1535	6
SDO (tx)	1100	1537 - 1663	6,7

\*Priority: 0 = highest priority, 7 = lowest priority

### USER MANUAL INCLINOMETER WITH CAN-BUS INTERFACE

#### 3.1.2 The Command Byte

The command byte contents the kind of telegram which is sent across the CAN network. One divides three kinds of telegrams: a Set-Parameter-Telegram (Domain Download), a Request-Telegram (Domain Upload) and Warnings.

The Request-Telegram is used by the master to read back stored parameters from a node.

Warnings are sent by the inclinometer to the master, if a sent telegram cannot be processed accordingly.

The Set-Parameter-Telegram is used to send parameter data to the inclinometer (node) for configuration.

Command	Function	Telegram	Description
22h	Domain Download	Request	Parameter to inclinometer
60h	Domain Download	Confirmation	Parameter received
40h	Domain Upload	Request	Parameter request
43h, 4Bh, 4Fh (*)	Domain Upload	Reply	Parameter to Master
80 h	Warning	Reply	Transmission error

(\*)The value of the command byte depends on the data length of the called parameter:

Command	Data length	Data length
43h	4 Byte	Unsigned 32
4Bh	2 Byte	Unsigned 16
4Fh	1 Byte	Unsigned 8

# POSITAL

## FRABA

### USER MANUAL

### INCLINOMETER WITH CAN-BUS INTERFACE

#### 3.1.3 The Object Directory

The data transmission according to CAL is realised exclusively by object oriented data messages. The objects are classified in groups by an index record. Each index entry can be subdivided by sub-indices. The overall layout of the standard object dictionary is shown beside:

Index (hex)	Object
0000	not used
0001-001F	Static Data Types
0020-003F	Complex Data Types
0040-005F	Manufacturer Specific Data Types
0060-0FFF	Reserved for further use
1000-1FFF	Communication Profile Area
2000-5FFF	Manufacturer Specific Profile Area
6000-9FFF	Standardised Device Profile Area
A000-FFFF	Reserved for further use

Following objects according to the communication profile CAN OPEN (refer toDS301) are implemented into the inclinometer encoder:

Index	Subindex	Object	Name	Data Length	Attr.
1000h		VAR	Device type	Unsigned32	const
1001h		VAR	error register	Unsigned8	ro
1002h		VAR	manufacturer status register	Unsigned32	ro
1003h		ARRAY	pre-defined error field	Unsigned32	ro
1004h			Reserved for compatibility reason		
1005h		VAR	COB-ID SYNC-message	Unsigned32	rw
1008h		VAR	device name	Vis-String	const
1009h		VAR	hardware version	Vis-String	const
100Ah		VAR	software version	Vis-String	const
100Bh			Reserved for compatibility reason		
1010h	1h	VAR	Store parameters	Unsigned32	rw
1011h	1h	VAR	Restor parameters	Unsigned32	rw
1016h		ARRAY	Consumer Heartbeat Time	Unsigned32	ro
1017h		VAR	Producer Heartbeat Time	Unsigned32	rw
1800h		RECORD	Communication parameter PDO 1		ro
1800h	0h	VAR	number of supp. entries	Unsigned8	ro
1800h	1h	VAR	COB-ID used by PDO	Unsigned32	rw
1800h	2h	VAR	transmission type	Unsigned8	rw
1801h		RECORD	Communication parameter PDO 2		ro
1801h	0h	VAR	number of supp. entries	Unsigned8	ro
1801h	1h	VAR	COB-ID used by PDO	Unsigned32	rw
1801h	2h	VAR	transmission type	Unsigned8	rw

### USER MANUAL INCLINOMETER WITH CAN-BUS INTERFACE

Index	Subindex	Objekt	Name	Datenlänge	Attr.
6000h		VAR	Resolution	Unsigned16	rw
6010h		VAR	Slope Longitudinal	Signed16	ro
6011h		VAR	Operating Parameter Longitudinal	Unsigned8	rw
6012h		VAR	Preset Longitudinal	Signed16	rw
6020h		VAR	Slope Lateral	Signed16	ro
6021h		VAR	Operating Parameter Lateral	Unsigned8	rw
6022h		VAR	Presetwert Lateral	Signed16	rw

Additionally, following manufacturer specific communication objects are implemented:

Index	Subindex	Objekt	Name	Datenlänge	Attr.
3000h		VAR	Knotennummer	Unsigned 8	rw
3001h		VAR	Datenrate	Unsigned 8	rw

Index	Subindex	Object	Name	Data length	Attr.
2200h		VAR	Cycle time	Unsigned16	rw

VAR:	Variable
RECORD:	Data field
ARRAY:	Data field
ro:	read only
rw:	read, write
wo:	write only

### USER MANUAL

#### INCLINOMETER WITH CAN-BUS INTERFACE

### 3.2 Operational Status

The inclinometer accesses the CAN network 4 s after power on in pre-operational status:

FC	NN	Comand	Index	Subindex	S-/P-Data	Description
1110	XXXXXXX					Boot-Up message

All values except the FC are hexadecimal

It is recommended, to set the parameters (see: 4 Programming) while the inclinometer is in the pre-operational status. During this status activity on the network is low what makes it easier to prove the

correctness of the sent/received SDOs. As it is not possible to send or receive PDOs in pre-operational status, stress for the inclinometer will be reduced.

#### 3.2.1 Status: Operational

To put one or all nodes in the operational state, following message is sent by the master:

FC	NN	Command	Index	Subindex	S-/P-Data	Description
0000 b	0 d	01 h	00			NMT-Start, all nodes
0000 b	0 d	01 h	NN			NMT-Start, NN

It is possible to put all the nodes in operational status (Index 0) or only one node (Index NN).

#### 3.2.2 Status: Pre-Operational

To set one node in the Pre-Operational state the following telegram has to be transmitted from the master:

FC	NN	Command	Index	Subindex	S-/P-Data	Description
0000 b	0 d	80 h	NN			NMT-PreOp, NN

NN: node number

### USER MANUAL INCLINOMETER WITH CAN-BUS INTERFACE

#### 3.2.3 Reset of the inclinometer

If a node is not functioning well, it is recommended to perform a RESET:

FC	NN	Command	Index	Subindex	S-/P-Data	Description
0000 b	0 d	81 h	NN			NMT-Reset, NN

NN: node number

The notified inclinometer accesses the bus in pre-operational status after resetting.

#### 3.3 Transmission of the Actual Position

The process value is sent across the CAN network with the following telegram:

COB-ID	Process value			
11 Bit	Byte 0	Byte 1	Byte 2	Byte 3
	$2^7$ to $2^0$	$2^{15}$ to $2^8$	$2^{23}$ to $2^{16}$	$2^{31}$ to $2^{24}$

The COB-ID contains the node number and the according PDO(rx). By default the process value is sent with the function code PDO(rx) 0011 and as a response to the Sync-telegram with the function code PDO(rx) 0101.

## 4. Programming

The setting of parameters should be done always in pre-operational status. The monitoring of the sent and received messages becomes much easier.

It is important to follow the presented sequence of the parameter settings. If values of parameters are not changed then they can be skipped.



**Following values are written in hexadecimal notation with the exception of the function code which value is given binary and the node number (decimal value).**

Every parameter has a general description and an example.

### USER MANUAL INCLINOMETER WITH CAN-BUS INTERFACE

#### 4.1 Resolution

The parameter Resolution is used to program the desired number of steps per 1°. The resolution is adjustable between 0,001° and 1°.

CMS	Index	Default value	Value range	Data length
SDO	6000h		Unsigned 16	Unsigned 16

#### General parameter description

Master to Inclinator:

Set-Parameter

FC	NN	Command	Index	Subindex	Service / Process data			
SDO(tx)		Download	6000h		Byte 4	Byte 5	Byte 6	Byte 7
1100 b	1-90 d	22	00   60	00	X	X	0	0

**X:** desired resolution

Only the follow values can be use to programming the resolution :

1h	0,001°
Ah	0,01°
64h	0,1°
3E8h	1°

After a successful transmission the inclinometer answered with the following confirmation telegram:

FC	NN	Command	Index	Subindex	Service / Process data			
SDO(rx)		Download	2101h		Byte 4	Byte 5	Byte 6	Byte 7
1011 b	1-90 d	60	01   21	00	00	00	00	00



### USER MANUAL INCLINOMETER WITH CAN-BUS INTERFACE

#### 4.1.1 Programming example: Resolution

Target: Inclinometer with 1 step per 1°

Value: 1000 = 3E8 h

Node Number NN = 1

Master to Inclinometer: Set-Parameter

FC	NN	Command	Index	Subindex	Service / Process data				
SDO(tx)		Download	6000h			Byte 4	Byte 5	Byte 6	Byte 7
1100 b	1-90 d	22	00	60	00	<b>E8</b>	<b>03</b>	0	0

Inclinometer to Master: Confirmation

FC	NN	Command	Index	Subindex	Service / Process data				
SDO(rx)		Download	6000h			Byte 4	Byte 5	Byte 6	Byte 7
1011 b	1-90 d	60	00	60	00	00	00	00	00

#### 4.2 Operating Parameter Longitudinal

This object determines the interpretation of the Slope Longitudinal value.

CMS	Index	Default value	Value range	Data length
SDO	6011h	0	Unsigned 8	Unsigned8

##### General parameter description

Master to Inclinometer: Set-Parameter

FC	NN	Command	Index	Subindex	Service / Process data				
SDO(tx)		Download	6011h			Byte 4	Byte 5	Byte 6	Byte 7
1100 b	1-90 d	22	11	60	00	<b>X</b>	0	0	0

X: Operating Parameter

Function	0	1
Scaling	X	Y

X: Slope Longitudinal = physically measured value + Offset

Y: Slope Longitudinal = physically measured value

**The inclinometer is setting on X by delivery.**

### USER MANUAL INCLINOMETER WITH CAN-BUS INTERFACE

#### 4.2.1 Programming example: Operating Parameter Longitudinal

Target: Setting the inclinometer on **Slope Longitudinal = physically measured value** .

Value:0

Master to Inclinometer: Set-Parameter

FC	NN	Command	Index		Subindex	Service / Process data			
SDO(tx)		Download	6011h			Byte 4	Byte 5	Byte 6	Byte 7
1100 b	01 d	22	11	60	00	<b>00</b>	00	00	00

Inclinometer to Master: Confirmation

FC	NN	Command	Index		Subindex	Service / Process data			
SDO(rx)		Download	6011h			Byte 4	Byte 5	Byte 6	Byte 7
1011 b	01 d	60	11	60	00	00	00	00	00

**The procedure to programming the Operating Parameter Lateral (object 6021h) is the same like Operating Parameter Longitudinal.**

### USER MANUAL INCLINOMETER WITH CAN-BUS INTERFACE

#### 4.3 Preset Value Longitudinal

The preset value is the desired position value, which should be reached at a certain physical position of the axis. The position value is set to the desired process value by the parameter preset.

CMS	Index	Default value	Value range	Data length
SDO	6012h	0h	0h - total resolution	Unsigned32

#### General parameter description

Master to inclinometer: Set-Parameter

FC	NN	Command	Index	Subindex	Service / Process data				
SDO(tx)		Download	6000h			Byte 4	Byte 5	Byte 6	Byte 7
1100 b	1-90 d	22	00	60	00	X	X	X	X

X: desired preset value

After a successful transmission the inclinometer answered with the following confirmation telegram:

FC	NN	Command	Index	Subindex	Service / Process data				
SDO(rx)		Download	6000h			Byte 4	Byte 5	Byte 6	Byte 7
1011 b	1-90 d	60	00	60	00	00	00	00	00

#### 4.3.1 Programming example: Preset value

Target: Inclinometer with the preset value 0

Preset value 0 is equivalent to X = 0h

Node number NN = 1

Master to Inclinometer: Set-Parameter

FC	NN	Command	Index	Subindex	Service / Process data				
SDO(tx)		Download	6000h			Byte 4	Byte 5	Byte 6	Byte 7
1100 b	01 d	22	00	60	00	00	00	00	00

Inclinometer to Master: Confirmation

FC	NN	Command	Index	Subindex	Service / Process data				
SDO(rx)		Download	6000h			Byte 4	Byte 5	Byte 6	Byte 7
1011 b	01 d	60	00	60	00	00	00	00	00

The procedure to programming the Preset Value Lateral (object 6022h) is the same like Preset Value Longitudinal.

### USER MANUAL

#### INCLINOMETER WITH CAN-BUS INTERFACE

#### 4.4 Node-Guarding

The NMT Master polls each NMT Slave at regular time intervals. This time-interval is called the Guard-Time and may be different for each

NMT Slave. The response of the NMT Slave contains the state of that NMT Slave.

##### 4.4.1 Guard-Time

CMS	Index	Default value	Value range	Data length
SDO	100Ch	0h	Unsigned 16	Unsigned 16

##### General parameter description

Master to inclinometer: Set-Parameter

FC	NN	Command	Index	Subindex	Service / Process data			
SDO(tx)		Download	100Ch		Byte 4	Byte 5	Byte 6	Byte 7
1100 b	1-90 d	22	0C	10	00	X	X	0

X: Time in ms

X is the Guard-Time which the NMT-Master polls the NMT-Slave

After a successful transmission the inclinometer answered with the following confirmation telegram:

FC	NN	Command	Index	Subindex	Service / Process data			
SDO(rx)		Download	100Ch		Byte 4	Byte 5	Byte 6	Byte 7
1011 b	1-90 d	60	0C	10	00	00	00	00

##### 4.4.2 Programming example: Guard-Time

Target: The Master send at a time of 1000ms

Guard-Time = Time 1000ms (03E8h)

Master to inclinometer: Set-Parameter

FC	NN	Command	Index	Subindex	Service / Process data			
SDO(tx)		Download	100Ch		Byte 4	Byte 5	Byte 6	Byte 7
1100 b	01 d	22	0C	10	00	<b>E8</b>	<b>03</b>	00

Inclinometer to Master: Confirmation

FC	NN	Command	Index	Subindex	Service / Process data			
SDO(rx)		Download	100Ch		Byte 4	Byte 5	Byte 6	Byte 7
1011 b	01 d	60	0C	10	00	00	00	00

### USER MANUAL INCLINOMETER WITH CAN-BUS INTERFACE

#### 4.4.3 Lifetime-Factor

The product from the Lifetime-Faktor and the Guard-Time is that time, where the Slave has to receive a remote-transmission-telegram from the Master.

CMS	Index	Defaultwert	Wertebereich	Datenlänge
SDO	100Dh	0h	Unsigned 8	Unsigned 8

#### General parameter description

Master to inclinometer: Set-Parameter

FC	NN	Command	Index	Subindex	Service / Process data			
SDO(tx)		Download	100Dh		Byte 4	Byte 5	Byte 6	Byte 7
1100 b	1-90 d	22	0D   10	00	X	0	0	0

X: Factor

After a successful transmission the inclinometer answered with the following confirmation telegram:

FC	NN	Command	Index	Subindex	Service / Process data			
SDO(rx)		Download	100Dh		Byte 4	Byte 5	Byte 6	Byte 7
1011 b	1-90 d	60	0D   10	00	00	00	00	00

#### 4.4.4 Programming example: Lifetime-Faktor

Target: The Slave has to receive a remote-transmission-telegram not later than 3000ms from the Master Faktor = 3

Master to inclinometer: Set-Parameter

FC	NN	Command	Index	Subindex	Service / Process data			
SDO(tx)		Download	100Dh		Byte 4	Byte 5	Byte 6	Byte 7
1100 b	01 d	22	0D   10	00	<b>3</b>	00	00	00

Inclinometer to Master: Confirmation

FC	NN	Command	Index	Subindex	Service / Process data			
SDO(rx)		Download	100Dh		Byte 4	Byte 5	Byte 6	Byte 7
1011 b	01 d	60	0D   10	00	00	00	00	00

**To switch off the Node-Guarding the Guard-Time and the Lifetime-Faktor has to set to zero.**

### USER MANUAL INCLINOMETER WITH CAN-BUS INTERFACE

#### 4.5 Heartbeat-Function

With the Heartbeat-Function each node can control another node in a network.

For more information please look to the specification DS301Vers4.

##### 4.5.1 Heartbeat-Consumer:

CMS	Index	Default value	Value range	Data length
SDO	1016h	0h	Unsigned 32	Unsigned 32

#### General parameter description

Master to inclinometer: Set-Parameter

FC	NN	Command	Index	Subindex	Service / Process data				
SDO(tx)		Download	1016h		Byte 4	Byte 5	Byte 6	Byte 7	
1100 b	1-90 d	22	16	10	01	X	X	Y	0

X: Time in ms

To ensure a secure functionality the Consumer-Time has to be approximately 100ms greater than the Producer- time.

Y: Node number of the producer

After a successful transmission the inclinometer answered with the following confirmation telegram:

FC	NN	Command	Index	Subindex	Service / Process data				
SDO(rx)		Download	1016h		Byte 4	Byte 5	Byte 6	Byte 7	
1011 b	1-90 d	60	16	10	01	00	00	00	00

### USER MANUAL INCLINOMETER WITH CAN-BUS INTERFACE

#### 4.5.2 Programming example: Heartbeat-Consumer

Target: The Producer send with 1000ms and contains the node number 1

Consumer = Time 1100ms = 044Ch, node number 1

Node number = 01h

Master to inclinometer: Set-Parameter

FC	NN	Command	Index		Subindex	Service / Process data			
SDO(tx)		Download	1016h			Byte 4	Byte 5	Byte 6	Byte 7
1100 b	01 d	22	16	10	01	<b>4C</b>	<b>04</b>	<b>01</b>	00

Inclinometer to Master: Confirmation

FC	NN	Command	Index		Subindex	Service / Process data			
SDO(rx)		Download	1016h			Byte 4	Byte 5	Byte 6	Byte 7
1011 b	01 d	60	16	10	01	00	00	00	00

#### 4.5.3 Heartbeat-Producer:

CMS	Index	Default value	Value range		Data length
SDO	1017h	0h	Unsigned 16		Unsigned 32

#### General parameter description

Master to inclinometer: Set-Parameter

FC	NN	Command	Index		Subindex	Service / Process data			
SDO(tx)		Download	1017h			Byte 4	Byte 5	Byte 6	Byte 7
1100 b	1-90 d	22	17	10	00	X	X	0	0

X: Time in ms

After a successful transmission the inclinometer answered with the following confirmation telegram:

FC	NN	Command	Index		Subindex	Service / Process data			
SDO(rx)		Download	1017h			Byte 4	Byte 5	Byte 6	Byte 7
1011 b	1-90 d	60	17	10	00	00	00	00	00

### USER MANUAL

#### INCLINOMETER WITH CAN-BUS INTERFACE

#### 4.5.4 Programming example: Heartbeat Producer

Target: Producer-Time 1000ms

Time in ms: X = 03E8h

Node number = 01h

Master to inclinometer: Set Parameter

FC	NN	Command	Index		Subindex	Service / Process data			
SDO(tx)		Download	1017h			Byte 4	Byte 5	Byte 6	Byte 7
1100 b	01 d	22	17	10	00	<b>E8</b>	<b>03</b>	00	00

Inclinometer to Master: Confirmation

FC	NN	Command	Index		Subindex	Service / Process data			
SDO(rx)		Download	1017h			Byte 4	Byte 5	Byte 6	Byte 7
1011 b	1-90 d	60	17	10	00	00	00	00	00

#### 4.6 Changing the node number

CMS	Index	Defaultvalue	Value range	Data length
SDO	3000h	20h	0h-89h	Unsigned 8

#### General parameter description

FC	KN	Command	Index		Subindex	Service / Process data			
SDO(tx)		Download	3000h			Byte 4	Byte 5	Byte 6	Byte 7
1100 b	1-90 d	22	00	30	00	<b>X</b>	00	00	00

After successful transmission the inclinometer answered with the following telegram:

FC	NN	Command	Index		Subindex	Service / Process data			
SDO(rx)		Download	3000h			Byte 4	Byte 5	Byte 6	Byte 7
1011 b	1-90 d	60	00	30	00	00	00	00	00



### USER MANUAL INCLINOMETER WITH CAN-BUS INTERFACE

#### 4.6.1 Example: Changing the node number

Target: Inclinometer with node number 5

**Default node number: 32 d**

The changed node number is confirmed by the inclinometer but only after a

- Store command (Objekt 2300 hex)
- Store command (Objekt 1010 hex) and NMT reset module or NMT reset communication

valid.

To adjust the node number only one byte is used whereby the inclinometer adds one to the programmed value.

Setting node number 5:

Bit	7	6	5	4	3	2	1	0
value	-	64	32	16	8	4	2	1
example	0	0	0	0	0	1	0	0

$1 \cdot 4 + 0 + 0 = 4 + 1 = 5$  node number

Master to Inclinometer:                      Set-Parameter

FC	NN	Command	Index		Subindex	Service / Process data			
SDO(tx)		Download	3000h			Byte 4	Byte 5	Byte 6	Byte 7
1100 b	32 d	22	00	30	00	<b>04</b>	00	00	00

X: 7 Bit to adjust the node number

Inclinometer to Master:                      Confirmation

FC	NN	Command	Index		Subindex	Service / Process data			
SDO(rx)		Download	3000h			Byte 4	Byte 5	Byte 6	Byte 7
1011 b	32 d	60	00	30	00	00	00	00	00

### USER MANUAL INCLINOMETER WITH CAN-BUS INTERFACE

#### 4.7 Adjusting the baud rate

CMS	Index	Default value	Value range	Data length
SDO	3001h	20h	0h-8h	Unsigned 8

#### General parameter description

FC	NN	Command	Index	Subindex	Service / Process data			
SDO(tx)		Download	3001h		Byte 4	Byte 5	Byte 6	Byte 7
1100 b	1-90 d	22	00   31	00	<b>X</b>	00	00	00

X: 4 Bit to adjust the Baud rate

After successful transmission the inclinometer answered with the following telegram:

FC	NN	Command	Index	Subindex	Service / Process data			
SDO(rx)		Download	3001h		Byte 4	Byte 5	Byte 6	Byte 7
1011 b	1-90 d	60	00   31	00	00	00	00	00

Nine different baud rates are provided. To adjust the baud rate only one byte is used.

#### Adjusting Baud rate:

Baud rate in kBit/s	Bit						
	7	6	5	4	3	2	1
10	0	0	0	0	0	0	0
20	0	0	0	0	0	0	1
50	0	0	0	0	0	1	0
100	0	0	0	0	0	1	1
125	0	0	0	0	1	0	0
250	0	0	0	0	1	0	1
500	0	0	0	0	1	1	0
800	0	0	0	0	1	1	1
1000	0	0	0	1	0	0	0

### USER MANUAL INCLINOMETER WITH CAN-BUS INTERFACE

The changing of the baud rate is confirmed by the inclinometer but is only saved after a

- Store command (object 2300 hex)
- Store command (object 1010 hex) and NMT Reset Modul or NMT Reset communication

#### 4.7.1 Example : Adjusting the baud rate

Target: Inclinometer with a baud rate of 250 kBAud

Default baud rate: 20 kBAud

Default node number: NN = 32 d

FC	NN	Command	Index		Subindex	Service-/Processdata			
SDO(tx)		Download	3001h			Byte 4	Byte 5	Byte 6	Byte 7
1100 b	32 d	22	00	31	00	<b>05</b>	00	00	00

After successful transmission the encoder answered with the following telegram:

FC	NN	Command	Index		Subindex	Service-/Processdata			
SDO(rx)		Download	3001h			Byte 4	Byte 5	Byte 6	Byte 7
1011 b	32 d	60	00	31	00	00	00	00	00

#### 4.8 Transmission Mode

##### 4.8.1 Cyclic Mode

The inclinometer transmits cyclic - without being called by the host - the current process value.

milliseconds for values between 1 ms and 65536 ms (e.g.: 64h = 100ms).

The cycle time can be programmed in

CMS	Index	Default value	Value range	Data length
SDO	2200h	64 h	1h - 10.000h	Unsigned16

#### General parameter description

Master to Inclinometer:

Set-Parameter

FC	NN	Command	Index		Subindex	Service / Process data			
SDO(tx)		Download	2200h			Byte 4	Byte 5	Byte 6	Byte 7
1100 b	1-90 d	22	00	22	00	<b>X</b>	<b>X</b>	00	00

**X**: desired cycle time

### USER MANUAL INCLINOMETER WITH CAN-BUS INTERFACE

Inclinometer to Master:                      Confirmation

FC	NN	Command	Index		Subindex	Service / Process data			
SDO(rx)		Download	2200h			Byte 4	Byte 5	Byte 6	Byte 7
1011 b	1-90 d	60	00	22	00	00	00	00	00

#### 4.8.2 Disable the cyclic mode

To switch off the cyclic mode of the inclinometer the following telegram (cyclic mode disable) can be sent:

Master to Inclinometer:                      Set-parameter

FC	NN	Command	Index		Subindex	Service / Process data			
SDO(tx)		Download	2200h		0h	Byte 4	Byte 5	Byte 6	Byte 7
1100 b	1-90 d	22	00	22	00	00	00	00	00

Inclinometer to Master:                      Confirmation

FC	NN	Command	Index		Subindex	Service / Process data			
SDO(rx)		Download	2200h		0h	Byte 4	Byte 5	Byte 6	Byte 7
1011 b	1-90 d	60	00	22	00	00	00	00	00

#### 4.8.3 Sync Mode

After reception of the SYNC-telegram by the host the inclinometer sends the actual position value. If multiple nodes are programmed for the SYNC-mode they answer following their COB-

Ids. The programming of an offset time is not applicable. It is also possible to program a number of SYNC telegrams which are ignored

CMS	Index	Subindex	Default value	Value range	Data length
SDO	1802h	2h	1h	1h - 100h	Unsigned 8

#### General parameter description

FC	NN	Command	Index		Subindex	Service / Process data			
SDO(tx)		Download	1802h		2h	Byte 4	Byte 5	Byte 6	Byte 7
1100 b	1-90 d	22	02	18	02	<b>X</b>	0	0	0

**X:** number of Sync-Telegrams after which the inclinometer sends the process value

### USER MANUAL INCLINOMETER WITH CAN-BUS INTERFACE

Inclinometer to Master:

Confirmation

FC	NN	Command	Index		Subindex	Service / Process data			
SDO(rx)		Download	1802h		2h	Byte 4	Byte 5	Byte 6	Byte 7
1011 b	1-90 d	60	02	18	02	00	00	00	00

Like the cyclic mode also the sync mode can be switched off the same way. To do this the PDO 2 must be addressed with the Index 1802h

#### 4.8.4 Example: Number of Sync telegrams

Target: Inclinometer with 3 SYNC telgrams

Number of SYNC telegrams: X = 03h

Node number: NN = 01 d

FC	NN	Command	Index		Subindex	Service / Process data			
SDO(tx)		Download	1802h		2h	Byte 4	Byte 5	Byte 6	Byte 7
1100 b	01 d	22	02	18	02	<b>03</b>	0	0	0

Absolute Inclinometer to Master:

Confirmation

FC	NN	Command	Index		Subindex	Service / Process data			
SDO(rx)		Download	1802h		2h	Byte 4	Byte 5	Byte 6	Byte 7
1011 b	01 d	60	02	18	02	00	00	00	00

#### 4.8.5 Polled Mode

By a remote-transmission-request telegram the connected host calls off the current process value. The inclinometer reads the current position value, calculates eventually set-parameters and sends back the obtained

process value by the same COB-ID. The PDO (rx) with the function code 0011 is used from the inclinometer to transmit the position value. This kind of Transmission mode must only be used in status operational.

CMS	Remote Transmission Request Bit (RTR)	Datenlänge
PDO	1	0

### USER MANUAL

#### INCLINOMETER WITH CAN-BUS INTERFACE

#### 4.9 Memory Transfer

The parameter settings can be stored in a non-volatile Flash-EPROM. The parameter settings are stored in RAM when being programmed, because of the limited number of burn cycles of the Flash-EEPROM ( $\approx 1.000$ ). When all the parameters are set and proved, they can be transferred in one burn cycle to the Flash-EEPROM by the parameter memory transfer.

The stored parameters are copied after a RESET (Power on, NMT-Reset) from the Flash-EPROM to the RAM (volatile memory).

The stored parameters are copied after a RESET (Power on, NMT-Reset) from the Flash-EPROM to the RAM (volatile memory).

Attention: The operating mode SYNC or CYCLIC is not saved in the inclinometer. After a reset or power up the cyclic mode is always started as standard. To switch off the cyclic on you must deactivate the cyclic mode in the state pre-operational. After that you could start the operational state.

CMS	Index	Value	Data Type
SDO	2300h	55 AA AA 55 h	Unsigned 32

Master to Inclinometer:                      Set-Parameter

FC	NN	Command	Index	Subindex	Service / Process data			
SDO(tx)		Download	2300h		Byte 4	Byte 5	Byte 6	Byte 7
1100	1-90 d	22	00    23	00	55	AA	AA	55

If the transfer is successful the inclinometer quotes after 4s with the pre-operational status with a Boot-Up message.

An additional possibility to store the parameter is to use the SDO object 1010. The following parameter has to be transmitted to the encoder:

CMS	Index	Value:	Data length
SDO	1010h	73 61 76 65 h	Unsigned 32

Master to Inclinometer:                      Set-Parameter

FC	NN	Command	Index	Subindex	Service / Process data			
SDO(tx)		Download	1010h		Byte 4	Byte 5	Byte 6	Byte 7
1100 b	1-90 d	22	10    10	00	73	61	76	65

### **USER MANUAL**

### **INCLINOMETER WITH CAN-BUS INTERFACE**

#### **4.10 Restore default parameters**

The default parameters can be restored. The already in the non-volatile memory programmed parameters are not overwritten. Only after a new store command the default parameters are stored in the non-volatile memory. To restore the default parameter the following telegram is used.

### USER MANUAL INCLINOMETER WITH CAN-BUS INTERFACE

CMS	Index	Value:	Data length
SDO	1011h	6C 6F 61 64 h	Unsigned 32

Master to Inclinator:                      Set-Parameter

FC	NN	Command	Index	Subindex	Service / Process data			
SDO(tx)		Download	1011h		Byte 4	Byte 5	Byte 6	Byte 7
1100 b	1-90 d	22	11    10	01	6C	6F	61	64

## 5. Technical Data

### 5.1. Electrical Data

Model	AGS 005	AGS 015	AGS030
Measuring range	+/- 5°	+/- 15°	+/- 30°
Resolution	0,001°	0,001°	0,005°
Accuracy (1)	+/-0,01°	+/-0,01°	+/-0,02°
Temperture Gradient (2)	+0.001°/K	+0.002°/K	+0.003°/K
Inclination angle in x and y (1)	+/-15°	+/-40°	+/-60°
Damping period 0° -> 5°	typical 1s 10%, 2s 1%, 3s 0,1%		
Interface	Transceiver according ISO 11898, galvanically isolated by opto-couplers		
Transmission rate	max. 1 Mbaud		
Device addressing	Adjustable by rotary switches		
Supply voltage (4)	10 – 30 V DC (absolute limits)		
Current consumption	typical 50 mA		
EMC	Emitted interference: EN 61000-6-3		
	Noise immunity: EN 61000-6-2		
Electrical life time	> 10 <sup>5</sup> h		

(1) T = +25°C, 90% total measurement range

(2) e.g. temperature drift AGS005 (T= 0°C...+55°C) = 55K \* 0,001°/K = 0,055°

(3) Supply voltage is applied.

(4) Inclinator should be connected only to subsequent electronics whose power supplies comply with EN 50178 (protective low voltage)

### 5.2 Mechanical Data

Housing	Aluminum
Lifetime	> 10 <sup>5</sup> h
Shock	A = 30g, t = 11ms, half sine (EN 60068-2-27)
Vibration	10 to 150 Hz, 2.5 mm amplitude, 5g const. acceleration, 1 octave / minute (EN 60068-2-6)
Weight (standard version)	350 g



### Environmental Conditions

Operating temperature	- 40 °C to +85 °C
Storage temperature	-40 °C to +85 °C
Humidity	98 % (without liquid state)
Protection class	IP 67 (connected) (EN 60529)

### 5.3 Mechanical Drawings

#### 5.3.1 Bottom view

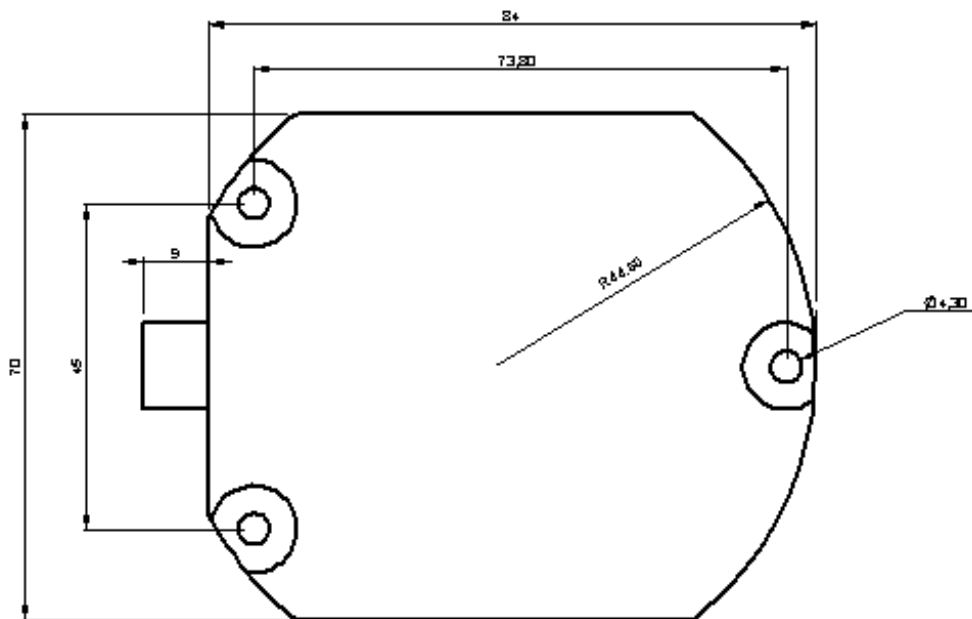

#### 5.3.2 Side view

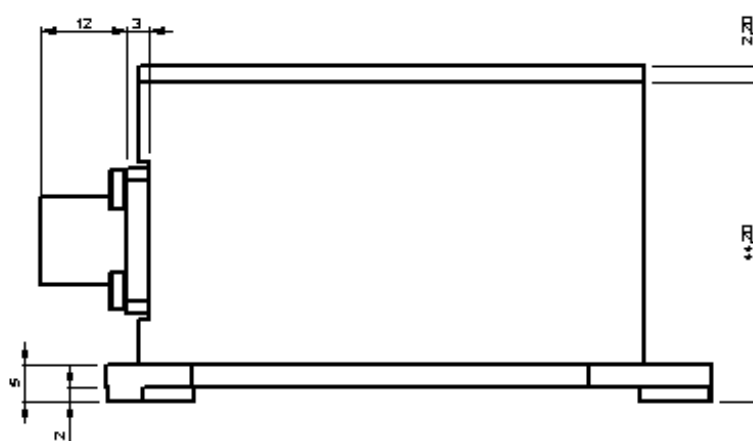

## USER MANUAL INCLINOMETER WITH CAN-BUS INTERFACE

### 5.3.3 Front view

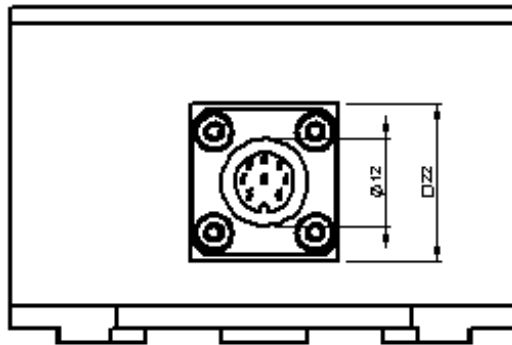

### 5.3.4 Top view

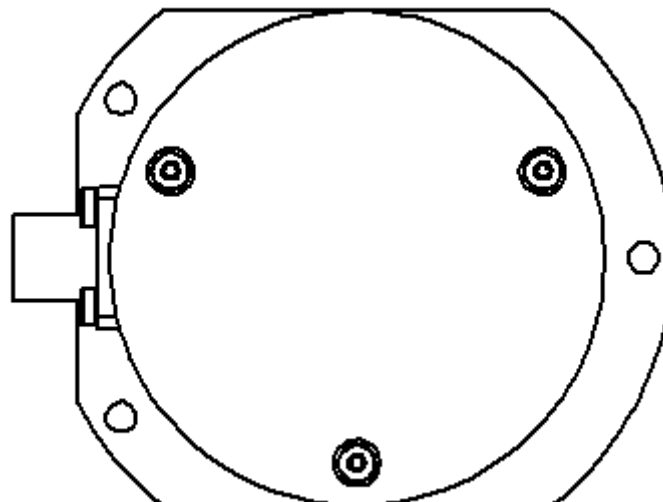

### Installation hints

Both the cable shielding and the metal housings of encoders and subsequent electronics have a shielding function. The housing must have the same potential and be connected to the main signal ground over the machine chassis or by means of a separate potential compensating line. Potential compensating lines should have a minimum cross section of 6 mm<sup>2</sup>.

Do not lay signal cable in the direct vicinity of interference sources (air clearance > 100 mm (4 in.).

A minimum spacing of 200 mm (8 in.) to inductors is usually required, for example in switch-mode power supplies.

Configure the signal lines for minimum length and avoid the use of intermediate terminals.

In metal cable ducts, sufficient decoupling of signal lines from interference signal transmitting cable can usually be achieved with a grounded partition.

## 6. Models / Ordering description

Description	Type key
TILTIX Inclinometer	<b>AGS-</b> ... 2 .. 1 H0 ... -
Measuring range	<b>005</b> <b>015</b> <b>030</b>
Number of axis	
Interface	<b>CA</b>
Version	
Mechanical construction	horizontal
Dynamik	2 mPas
Connection	connector, 8 pin <b>P8M</b> 1 m cable <b>CRW</b>
Option	without -

### USER MANUAL INCLINOMETER WITH CAN-BUS INTERFACE

#### 6.1 Accessories and documentation

Description		Typ
Mating connector		P8F
Cable	Cable STK 8, 2m, Connector P8F	P8F-STK8.2
	Cable STK 8, 5m, Connector P8F	P8F-STK8.5
User manual *	Installation and configuration manual, German	UMD-AGS-CA
User manual *	Installation and configuration manual, English	UME-AGS-CA
EDS-File *	Disc containing EDS-file for configuration	DK-AGS-CA

These can be downloaded free of charge from our webpage [www.posital.com](http://www.posital.com).

#### Disclaimer

FRABA N.V. all rights reserved. We do not assume responsibility for technical inaccuracies or omissions. Specifications are subject to change without notice.